

Technical data sheet

Product features



Fry-top griddle plate 100x45 gas grooved without cabinet

Model	SAP Code	00001123
FTRT-610G	A group of articles - web	Grills and grill plates



- Top type: Grooved
- Griddle dimensions [mm x mm]: 995 x 450
- Griddle thickness [mm]: 14.00
- Worktop material: Stainless steel
- Ignition: Piezo + večný plamen

SAP Code	00001123	Power gas [kW]	15.000
Net Width [mm]	1000	Type of gas	Natural gas, propane butane
Net Depth [mm]	600	Griddle dimensions [mm x mm]	995 x 450
Net Height [mm]	280	Top type	Grooved
Net Weight [kg]	80.00		

Technical data sheet

Technical drawing



Fry-top griddle plate 100x45 gas grooved without cabinet

Model	SAP Code	00001123
FTRT-610G	A group of articles - web	Grills and grill plates

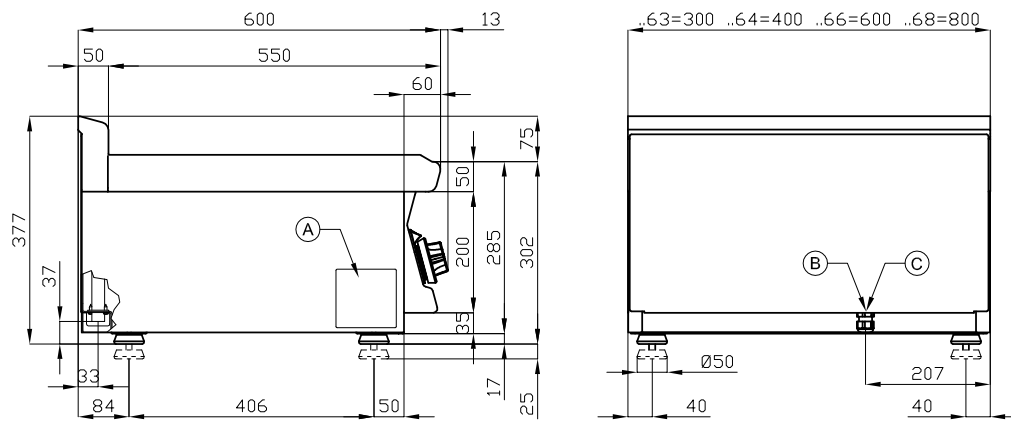

A	Data plate		C	Gas connection	ISO 7-1 1/2" M
---	------------	--	---	----------------	----------------

Technical data sheet

Product benefits



Fry-top griddle plate 100x45 gas grooved without cabinet

Model	SAP Code	00001123
FTRT-610G	A group of articles - web	Grills and grill plates

1

Safety element – thermocouple

safe service for staff
there is no unnecessary gas leakage
long life

- savings on service interventions
- easier and faster operation

7

Cooking unit for use on a table or on a base

variable use
the possibility of placement in smaller spaces

- easy handling
- cost savings on substructure

2

All-stainless design

long life
resistance of AISI 304 stainless steel material
the material does not cut

- savings on service interventions
- easy cleaning and maintenance of equipment

3

Degree of protection of the control elements IPX5

maintenance-free system
resistance to splash water
long life

- savings on service interventions
- easy cleaning and maintenance of equipment

4

Outlet for waste liquids

ensures that oil drips into the socket

- easy maintenance
- easy cleaning

5

High detachable hem

better hygienic conditions
preventing grease from splashing onto ancillary equipment

- easy maintenance
- easy cleaning

6

Ribbed steel plate

fast heat transfer and the surface will not be scratched
a good warming of the meat with a groove

- time-saving in food preparation
- easy preparation of good-looking food

Technical data sheet

Technical parameters



Fry-top griddle plate 100x45 gas grooved without cabinet

Model	SAP Code	00001123
FTRT-610G	A group of articles - web	Grills and grill plates

1. SAP Code:

00001123

2. Net Width [mm]:

1000

3. Net Depth [mm]:

600

4. Net Height [mm]:

280

5. Net Weight [kg]:

80.00

6. Gross Width [mm]:

1030

7. Gross depth [mm]:

690

8. Gross Height [mm]:

610

9. Gross Weight [kg]:

89.00

10. Device type:

Gas unit

11. Construction type of device:

Table top

12. Power gas [kW]:

15.000

13. Ignition:

Piezo + večný plamen

14. Type of gas:

Natural gas, propane butane

15. Protection of controls:

IPX5

16. Exterior color of the device:

Stainless steel

17. Material:

AISI 304 top plate and cladding

18. Worktop material:

Stainless steel

19. Worktop Thickness [mm]:

2.50

20. Service accessibility:

Trough the frontal panel

21. Adjustable feet:

Yes

22. Griddle dimensions [mm x mm]:

995 x 450

23. Griddle thickness [mm]:

14.00

24. Top type:

Grooved

25. Connection to a ball valve:

1/2